

SECTION 686

VIDEO MONITORING SUBSYSTEM

(NOTE: This only applies if any new video subsystem equipment is added to the current complement of equipment that the City of Tallahassee utilizes. All equipment furnished and installed shall conform to the following specifications.)

The Tallahassee Advanced Transportation Management System (ATMS) video monitoring subsystem shall be a complete and operating system consisting of field located video camera assemblies; field communications transceivers; dedicated fibers within the TATMS cable plant for transmitting video images to the central control equipment and camera control commands to the field located cameras; central site communications transceivers; a video switcher; a video controller; twenty-four 20-inch color monitors and an 80 inch color display; and additional miscellaneous hardware and devices necessary to provide the functions described in these Special Provisions. The various components of the system shall be fully compatible (operationally and electrically) with each other and existing equipment in the TATMS domain.

A line drawing representing a potential configuration of the system is included as Figure 1. This figure is not necessarily representative of all components necessary to provide the functions defined in these Special Provisions.

686-1 General Requirements

The following requirements shall be applicable to all components of the TATMS Video Monitoring Subsystem.

686-1.1 Environmental and Electrical Requirements

All field located equipment, including the video camera assemblies and field communications transceivers, shall be designed to operate within the rugged and extreme conditions, including lightning, wind, high humidity, and temperature, associated with southern field locations.

All field located video system components, while housed in their associated enclosures (with heaters / blowers, as required), shall be designed to operate within an ambient temperature range of 10 °F (-230 °C) to 1400 °F (600 °C) and with a relative humidity of up to 100%.

FIGURE 1

VIDEO MONITORING SUBSYSTEM (TYPICAL CONFIGURATION)

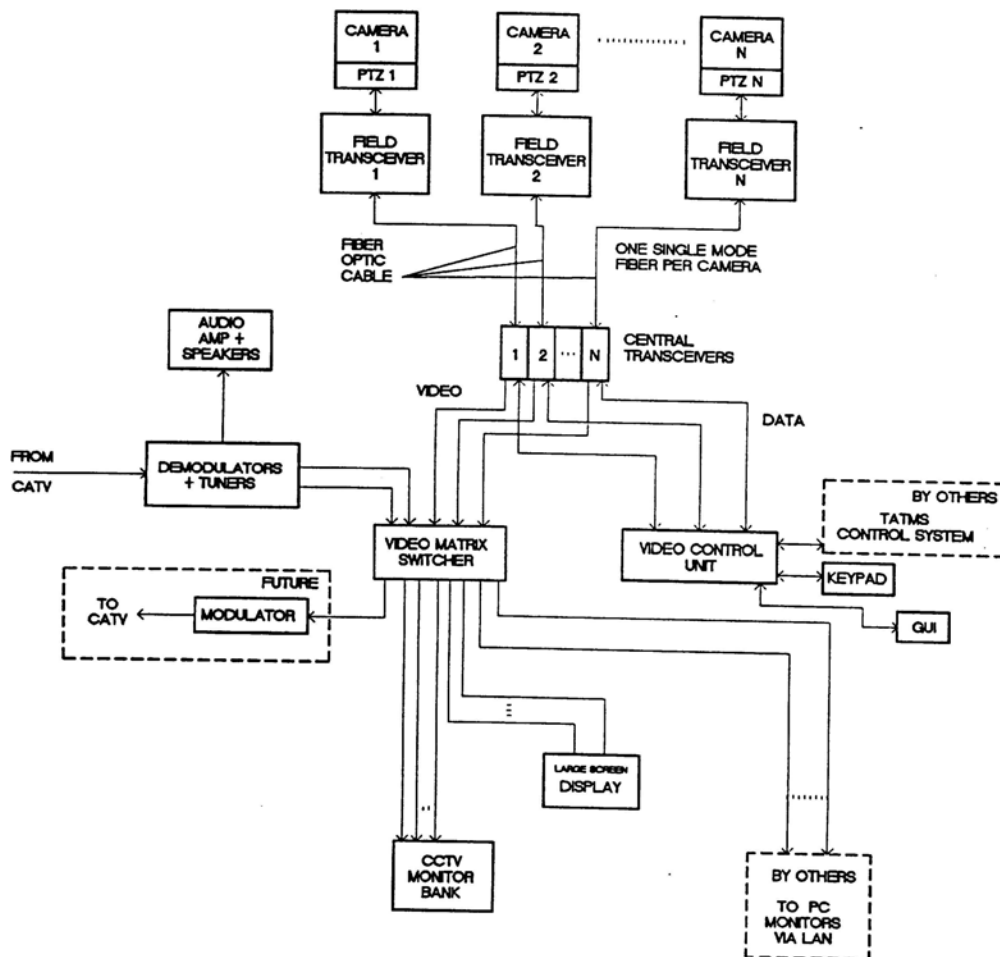

The design of these components shall include provisions for lightning and surge protection appropriate for the lightning conditions encountered in the Tallahassee area and as approved by the Engineer.

The video camera assemblies and field communications transceivers shall be designed to withstand and operate properly under the full range of environmental conditions encountered in the Tallahassee area, including dust, dirt, pollen, fumes, wind, high humidity, lightning, rain, sleet, hail, and snow, without damage to the equipment or creating the need for frequent or special maintenance procedures.

Video camera equipment and its associated mounting hardware shall be designed to withstand sustained wind loading in excess of 100 miles per hour. The Contractor shall provide certification that the camera assemblies have been tested, by an independent test laboratory, under such loading conditions.

All equipment to be located within the Transportation Management Center at City Hall shall be designed for an ambient temperature range of 32 °F (0 °C) to 122 °F (50 °C), with a relative humidity of up to 95%, non-condensing.

All components of the video monitoring subsystem shall be designed to operate on standard 120 VAC electrical service, operating over a range of 105 to 125 VAC at 60 Hz. The equipment located within the Transportation Management System will be powered through the Uninterruptible Power Supply Generator backup electrical system. Field equipment will be powered through the utility power source available at the local intersection, and shall remain operational (cameras will generate reasonable images and communications will operate, although with a possibly degraded performance) over a wider range of 95 to 130 VAC.

686-1.2 Compatibility Within the Video Monitoring Subsystem

All components of the Video Monitoring Subsystem shall be totally compatible with each other in both operation and electrical interface.

The video monitoring subsystem shall be a complete and operating system as specified in these Special Provisions.

686-1.3 Applicable Industry Standards

All video monitoring subsystem equipment shall be in compliance with the appropriate standards of the National Television Standards Committee (NTSC). All equipment furnished under this contract shall be listed by Underwriters Laboratory (UL).

686-2 Camera Assemblies

One type of camera assembly have been defined for the Tallahassee Advanced Transportation Management System. The Type I assembly is a full featured color camera enclosed in a discrete dome enclosure, with all related equipment for a complete installation.

All assemblies shall be designed for long life and with a minimum reported MTBF of similar units of at least 3.5 years.

686-2.1 Type I Closed Circuit Television Camera Assembly (Dome Enclosure)

This subsection describes the minimum acceptable design and operating requirements for a remotely controlled, dome enclosed, color, closed circuit television camera assembly for use in the Tallahassee Advanced Transportation Management System. The camera assembly shall be a Ultrak KD6 Weatherdome or approved equal, and shall be identical to existing units already in use by the City of Tallahassee.

The Type I Closed Circuit Television (CCTV) Camera Assembly shall consist of a complete, field located assembly, and shall consist of a weatherproof dome enclosure, color camera, zoom lens, pan-tilt mechanism, control circuitry, cabling, mounting brackets, and all related and miscellaneous equipment and incidental components for a complete and fully operational assembly.

686-2.1.1 Color Camera

The CCTV camera shall utilize a 1/2" or 1/3" format, interline transfer, Charged Coupled Device (CCD) image sensor which has been designed to require no preventive maintenance or adjustments. The CCD shall be blemish-free and shall be designed to minimize or eliminate transfer smear and ensure acceptable operation during minimal lighting conditions. The camera shall be designed such that there is no visible degradation of the video image generated by the CCD over a five year period.

At least 450 horizontal TV lines shall be produced by the camera assembly. At least 768 horizontal and 492 vertical active pixels shall be produced by the image sensor.

The camera shall be capable of unattended, continuous 24 hours per day operation in an outside environment.

The camera shall be fully integrated with the zoom lens described elsewhere within this specification. The camera shall accept a standard CS-mount zoom

lens and shall be equipped with an auto-iris lens connector compatible with the zoom lens supplied.

The camera shall produce NTSC compatible video utilizing a 1-Volt Peak to Peak composite output. The camera shall be fully compliant with all aspects of the NTSC specification.

The camera shall be equipped with AGC (Automatic Gain Control) with a 0 - 20 dB range. The AGC feature shall be locally and remotely selectable (On/Off) and be equipped with a variable peak average control.

Useable video (80% Peak to Peak Video Output Signal) shall be obtainable with a scene illumination of 0.2 lux with AGC on, based on an f/1.4 lens with a 75% highlight reflectance, measured at the camera face plate.

The signal-to-noise ratio, with AGC off, shall exceed 50 dB.

Synchronization shall be provided to allow for roll-free vertical interval switching at the Transportation Management Center.

A variable speed electronic shutter shall also be provided. The automatic shutter speeds shall be remotely and locally adjustable from 1/60 to 1/10,000 in a minimum of eight steps.

The camera shall have continuous automatic (through the lens) white balance control and back light compensation circuitry to adjust the picture dynamically in response to the varying light conditions encountered in outside environments. Images with an appropriate color balance shall be obtainable within all specified illumination conditions.

686-2.1.2 Zoom Lens

A fully motorized zoom lens fully compatible with the camera specified above shall be supplied. The focal length of the zoom lens shall be variable between 8.0 and 80 mm. The lens shall have an auto-iris capability, with manual override capability, compatible with the camera. The speed of the lens shall be at least f 1.4.

The zoom magnification shall be fully controllable. The motors controlling the Iris, Zoom, and Focus shall be protected to prevent damage due to overloads. The following lens travel times from limit to limit shall define the acceptable ranges:

Iris -	=	0 to 3 Seconds
Zoom -	=	0 to 3 Seconds
Focus -	=	0 to 3 Seconds

The zoom lens shall be equipped with a means to provide position feedback to assist in positioning the unit to preset scenes. The feedback information shall be interfaced via the control system's local camera receiver driver unit.

The lens shall provide both automatic and remote manual control of the iris.

686-2.1.3 Pan-Tilt Mechanism

The camera and lens assembly shall be integrated within a full-featured pan-tilt drive assembly. The pan-tilt drive mechanism shall allow the camera to be panned horizontally a minimum of 360 degrees at a variable pan rate of 0.5 to 70 degrees per second, and vertically from horizontal down to -90 degrees (straight down), at a variable pan rate of 0.5 to 60 degrees per second.

The pan-tilt drive mechanism shall be designed to prevent camera drift and minimize backlash, and shall include a stabilization kit to prevent movement caused by weather elements.

Internal electrical connections shall be made in a manner to permit the unrestricted operation of the pan-tilt mechanism.

The pan-tilt drive mechanism shall be equipped with a position feedback monitor which shall assist in positioning the unit to preset positions.

The pan-tilt mechanism, including the camera and lens package, shall be easily and quickly removable and replaceable utilizing a quick disconnect mounting connector and a single electrical connector.

686-2.1.4 Dome Enclosure

The camera, lens, and pan-tilt mechanism shall be housed within a dome enclosure system designed for outdoor video monitoring applications.

The dome enclosure shall consist of a rugged, weatherized, spherical enclosure. The lower half of the enclosure shall be a clear, optically correct, acrylic dome. The upper half of the dome may consist of a single hemispherical piece or two nested hemispherical pieces designed to reduce the effects of rain and sun on the lower portion of the dome. The upper part of the enclosure shall be a white, ABS plastic or acrylic, UV protected dome housing. The diameter of the upper half of the dome assembly shall be at least three inches greater than the diameter of the lower half of the dome assembly, providing a rain and sun shade for the optical dome surface.

The upper and lower portions of the dome shall intermate to form a weatherproof seal; however, access to the camera by opening the dome enclosure shall be easily accomplished without tools. The lower half of the dome shall be attached, by plastic coated cable or other acceptable means, to the upper half, to allow the clear half to hang safely when the enclosure is opened for servicing.

The dome shall include a thermostatically controlled, adequately sized heater / blower assembly to maintain proper camera operating temperatures. In addition, the dome shall include a weatherproof ventilation system to allow the exchange of air within the dome.

One spare clear dome and one spare smoke dome shall be furnished for every ten camera assemblies provided.

686-2.1.5 Mounting Bracket

The dome enclosure shall be suspended by a rigid mounting bracket, typically attached to an existing signal pole as shown in the Plans. The bracket and enclosure mounting shall be designed to minimize wind movement and vibration. The assembly shall be designed to withstand sustained winds in excess of 100 miles per hour. The bracket and mounting devices to be utilized in this project shall include the certification of design by a Florida registered Professional Engineer.

686-2.2 Deleted

686-2.3 Video Camera | Pan Tilt Zoom Control Equipment

Each camera assembly shall include the necessary electronics to fully control and monitor the Pan-Tilt-Zoom mechanisms. This equipment shall include a rack mountable local control panel, installed within the local intersection controller cabinet, which shall allow the connection of a test monitor and a test controller, and a switch to select between local and remote operation.

The receiver shall interface the camera's Pan, Tilt, Zoom and Auxiliary functions with ASCII codes for operation over fiber optic data transceivers to interface with the central control system.

The control equipment shall include an RS-232 / RS-422 interface port which can provide full control and feedback. The Pan-Tilt-Zoom receiver shall interface to the central control equipment utilizing an asynchronous protocol. In addition, feedback shall be provided which contains the current coordinates of the Pan-Tilt-Zoom mountings.

The control equipment shall be capable of storing at least 16 preset combinations of Pan-Tilt-Zoom.

Cabling between the camera and the control equipment shall be protected from the transmission of damaging voltage surges or lightning.

One (1) local controller panel shall be furnished with each traffic controller cabinet assembly furnished under this contract.

686-2.4 Installation of Camera Assembly

Each CCTV Camera Assembly shall consist of a complete, field located assembly³ and shall include the furnishing and installation of all necessary components, including camera, control equipment, cabling, mounting brackets, and all related and miscellaneous equipment and incidental components for a complete and fully operational assembly.

At installation sites that are part of existing signalized intersections, cabling between the camera and the control equipment located within the local controller cabinet shall

be furnished and installed along existing pathways, if available, or utilizing new conduit to be furnished and installed as an incidental part of this item. The cable routing and installation shall be as approved by the Engineer. All installations shall be in accordance with the Plans.

Where the camera is to be located on a concrete, wood, or steel signal span wire pole, on the same quadrant of the intersection as the controller cabinet, camera cabling shall be installed within the communications riser and conduit system to the cabinet, if such riser is available or is being installed at this location; alternatively, the cabling shall be installed within other existing risers or pole weather-heads, as approved by the Engineer. If no such suitable existing route exists, the Contractor shall install a new external riser assembly to the closest junction box; such riser assembly to be furnished and installed as an incidental part of this item.

Where the camera is to be located on a signal pole on a quadrant other than that referenced above, the cabling shall first be located in the most direct manner from the camera to the pole on the quadrant adjacent to the cabinet, along the existing signal span. The Contractor shall propose the routing for the approval of the Engineer. All such wiring shall be performed in conformance with the requirements of the Florida Department of Transportation.

Where the camera is to be located on a mast arm structure, the cabling shall be routed into the pole and through the existing conduit system to the controller cabinet. The Contractor shall propose the routing for the approval of the Engineer.

Where the camera is to be located on a pole that is to be furnished as part of this contract, separate pay items for the pole, conduit, control cabinet, and related materials will be shown in the Plans. The Contractor shall be responsible for providing all design submittals necessary for the installation of the pole and related appurtenances.

The camera support bracket shall be electrically grounded to the pole or pole ground.

686-3 Video Monitoring Subsystem Communications Equipment

The Video Monitoring subsystem communications equipment shall provide for bi-directional flow of data over a single fiber optic fiber. The video image and camera feedback signals shall be transmitted from the field transceiver to the central transceiver; camera control signals shall be transmitted from the central transceiver to the field transceiver.

One field located transceiver and one central site transceiver shall be furnished and installed for each camera assembly furnished and installed as part of this project.

686-3.1 Field Located Transceivers

The field located fiber optic video and data transceivers shall convert a standard NTSC CCTV signal and bi-directional data (PTZ) signal into a Digital light for

transmission over a single mode optical fiber for distances of up to 54 km. The emitter of the transceivers shall be a laser diode; edge-emitting LED's are not acceptable. The transceivers shall be provided with four diagnostic LED's.

Field located transceivers shall be either rack mounted or wall mounted as best indicated to interface with the controller cabinet located camera control equipment.

686-3.2 Central Site Transceivers

Each central site located fiber optic video and data transceiver shall receive a video signal from the field located transceiver and simultaneously send and receive data signals in both directions on one single mode optical fiber.

The central site transceiver, when used with the field located transceiver shall provide electrical interfaces for RS-232 / RS-422 data transmission. The data transmission shall not require any adjustments for data rate or data encoding.

Central site transceivers shall be designed to be housed in a 19-inch EIA rack mounted chassis designed to accommodate up to 9 double width (18 single width) transceivers. Each chassis shall include a rack power supply suitably rated and protected by fusing for the electrical requirements of the transceivers. The chassis shall be mounted in an attractively designed 19-inch EIA rack cabinet designed to accommodate a minimum of eight chassis. An attractive door with Plexiglas viewing panel shall be included.

All fiber optic and electrical cables shall be routed to and from the rear of the rack cabinet. A power strip shall be installed at the bottom of the cabinet to provide power to the chassis. A minimum of eight outlets shall be provided.

All chassis shall be designed so that any failure in any chassis shall not short-circuit the power supply or affect the performance or operation of any other module in that chassis or within the cabinet.

686-3.3 Transceiver Technical Requirements

All equipment shall be Entela certified to meet UL 60950 (2000). All modules must be field replaceable without optical or electrical adjustments. Transceivers shall be Optelecom Model 9432DT(BBB)/SM-FC-1315 or Model 9432DR(BBB)/SM-FC-1513 or approved equal and shall be compatible with existing equipment. The following technical requirements shall apply:

Video Receiver Sensitivity	1.0 Microwatts (-30 dBm) at 1300 nm and 1550 nm
Video Input/Output Impedance:	75 ohms +/- 5%
Video Input/Output Level:	1.0 to 1.4 Volts peak-to-peak
Differential Gain Error:	=0.7 Percent
Differential Phase Error:	=0.7 Degrees
Tilt:	<1 Percent

Luminance Non-Linearity:	<5 Percent
Weighted Signal to Noise Ratio	= 67 dB at 1 microwatt (-30 dBm) input power
Optical Detector:	Pin Diode
Frequency Response:	2 Hertz to 15 MHz (-3 dB)
Operating Temperature:	-40 to +70 Degrees C.
Relative Humidity:	0 to 95 Percent (non-condensing)
Video Connector:	BNC with gold plated center pin
Optical Connector:	Single Mode FC
Data Interfaces:	RS-232 / RS-422,
Data Rate:	DC to 115.2Kbps
Encoding:	10 Bit linear PCM
BER	1 x E-9

The transceiver shall include four LED indicators for troubleshooting, a typical transmitting distance range of 54 km

686-4 Central Control Equipment

This section shall cover the work of furnishing and installing the video system central control equipment in accordance with the provisions of this section and the details shown in the plans.

686-4.1 General Requirements

This section defines the material requirements for the video control equipment₁ consisting of the video switcher, video control system, display monitors₃ video system diagnostic software, and test and maintenance equipment and training courses on video system maintenance for this project.

The purpose of these specifications is to describe the minimum acceptable design and operating requirements for this equipment. The video control equipment includes the components for automatically and electronically switching the various CCTV video inputs from the field located cameras to the display equipment and transportation management center computers, under computer control and manual command.

The video control equipment will be located within the City of Tallahassee Transportation Management Center, located on the first floor of Tallahassee City Hall. The video control equipment will be utilized within an interior air-conditioned environment.

The video control equipment shall be compatible with National Television Standards Committee (NTSC) compatible video sources, and the CCTV camera assemblies defined elsewhere within these special provisions. The central control equipment shall be fully compatible and integrated with all the video subsystem equipment to be provided under this contract.

The video control equipment (switcher, control unit, and transceivers) shall be rack mounted in an attractively designed 19 inch EIA rack cabinet (or cabinets) designed to accommodate this type of equipment. An attractive door with plexiglass viewing

panel shall be included. All fiber patch cables between the fiber optic communications termination panel and the transceivers shall be furnished and installed.

686-4.2 Video Switcher

The video switcher shall consist of a rack mounted electronic device to switch video signals that are received from the various camera sites, via the fiber optic communications system, to designated video monitors, computers, and other outputs, as defined within these Special Provisions. The video switcher shall operate under both computer control and manual operator control.

The video switcher shall provide a capacity for the following video signal inputs:

- One hundred (100) video cameras
- Two (2) video receivers (see Subsection 686-4.6)
- Four (4) independent inputs for text or graphic screens from the TATMS computer.

All existing equipment to provide this input capacity was provided as part of the City of Tallahassee Fiber Optic Installation Contract.

The video switcher shall provide the capacity for the following video outputs:

- Twenty-four (24) 20-inch color monitors, to display video images from the cameras or the video receivers.
- One (1) 80-inch color display unit, to display video images from the cameras, video receivers, or TATMS graphics. It shall be possible to show multiple images concurrently on this display unit.
- Twelve (12) computer workstations, to display video images from the cameras or the video receivers within the screens of the workstations. Workstations will be connected to the TATMS computer LAN; the video switcher should interface with the LAN. The LAN and the workstations themselves are not to be furnished as part of this Contract: the Contractor shall provide the necessary documentation and hardware requirements to allow the TATMS software supplier to interface with the system.
- Two (2) outputs for future media connections to allow the display of images from the cameras.
- One (1) output for a future Police Department connection, to allow the display of images from the cameras.
- One (1) output for a future Fire Department connection, to allow the display of images from the cameras.
- One (1) spare output (for future assignment) to allow the display of images from cameras, video receivers, and TATMS graphics.

All required hardware over and above the existing equipment and hardware provided as part of the City of Tallahassee Fiber Optic Installation Contract shall be the responsibility of the contractor furnishing and installing the upgrade.

It shall be possible to display any video image from a camera on any output or

multiple outputs. It shall be possible to display any image from the video receivers on any output or multiple outputs. It shall be possible to display any of the TATMS graphics on the monitors.

The video switcher shall include an EIA RS-232C serial computer interface for communications with the TATMS computer system. This interface shall be the means for executing the video switch command functions issued by the TATMS computer.

The video switcher shall provide a camera / monitor sequencing function to automatically switch between user defined video input signals, retaining each selected video circuit for a user specified duration. It is envisioned that Transportation Management Center staff will configure the video so that individual monitors will be assigned to specified arterials or sections of the city; the switcher would automatically display, in sequence, the video inputs from within the specified section.

The video switcher shall be provided with a controller keyboard / keypad, to allow the manual control of the video switcher. The keyboard / keypad shall be located remotely from the switcher, on the console of the Transportation Management Center.

The video switcher shall provide the capability of entering, storing, and generating, a sixteen character alphanumeric identifier for each camera and preset. The video switcher shall include a means for entering the identification into the system, and superimposing this identifier on one or more video input sources, before the signal is presented to the designated output. The alphanumeric identifier function may be implemented into the video controller, instead of the video switcher, or partially in both units, at the discretion of the supplier. The video switcher shall be able to implement a switch between video images without creating a vertical roll transition on the output monitor or computer display.

The video switcher shall be able to route a single input to any number of outputs simultaneously. The video switcher shall provide a camera / monitoring sequence function, whereas a sequence of input to output switching may be programmed, stored, and replayed. The sequencing function shall support variable dwell times, in the range of from one to sixty seconds for each image. The video switcher shall also support the automatic looping of the programmed sequence, wherein the programmed sequence continues to repeat until a manual override is implemented. Dwell times and sequencing data shall be stored within the switcher and shall be protected from data loss during power outages.

The video switcher shall also provide the capability to switch both the video signals originating from the cameras and the Pan-Tilt-Zoom signals originating from the computer or the operator, to ensure that the operator can simultaneously control the Pan-Tilt-Zoom while observing the video output for a given camera.

The video switcher shall support the control of all of its functions from a host computer system (the TATMS control system). The control by the host computer system shall be accomplished via communications using a standard EIA RS - 232C serial interface. The video switcher control protocol shall use a standard ASCII data

format for its control commands. The supplier of the video switcher shall provide a complete, accurate, and detailed description of the video switcher host computer control protocol to the Engineer, as part of the initial submittal process. A second copy of the control protocol shall be included with the video switcher equipment documentation.

The video switcher and its associated cables and connectors shall not degrade or destroy the quality of the video signal.

686-4.3 Video Controller

A single, microcomputer-based, video camera controller shall control the full compliment of installed and anticipated cameras in the field, for a minimum of one hundred (100) cameras.

The camera controller configuration shall include all electronics, cables, connectors, and interfaces required to accomplish the functions described in these special provisions.

The system shall support a minimum of sixteen pan, tilt, and zoom (PTZ) presets per camera.

The execution of all required camera control commands from the host computer shall be through a EIA RS 232C serial data interface.

A camera controller shall allow an operator to control all camera and lens functions, including pan, tilt, and zoom. This control shall include all the capabilities available with the field camera assembly. The camera controller shall allow an operator to perform camera-to-monitor video switching from a single keyboard / controller, and via a master RS-232 / RS-422 port.

Commands from the RS-232 / RS-422 port, video switcher, and controller shall be implemented independently of each other. However, a mechanism shall exist to link the switcher and control functions when the devices are executed from their associated manual control panels.

The camera controller shall have a password priority system that enables control of operator restrictions and capabilities. Priority, partitioning, lockout shall be user programmable by level of priority.

The camera controller shall support alarms for system and field status.

The camera controller shall support camera position presets, camera sequencing, event alarms programming, partitioning, and block switching. These functions shall be user programmable. The camera controller shall have the capability to upload and download camera control programs from the host PC computer interface. Remote access for these functions shall be required. The video controller shall have the ability to superimpose a camera identification number and description onto the video received at the input port. This feature shall be controllable from the manual control panel or the central RS-232 interface.

The video controller shall incorporate a GUI interface for manual control. The system shall be designed so that the GUI interface is able to be integrated into the TATMS software. The System Supplier shall provide documentation and support to the TATMS System Software Supplier for integration.

The video controller shall also include a remote keypad / joystick interface to be located on the Transportation Management Center console. This unit may be integral to the remote video switcher control to be located at the same console.

686-4.4 Video Monitors

The Fiber Optic Contractor for the City of Tallahassee furnished and installed a video monitor system, consisting of twenty-four (24) identical 20-inch color monitors in a rack mounting system, and a 80-inch color display unit, all designed for an attractive installation within the wall openings provided in the Transportation Management Center. The Contractor coordinated with the Architectural Contractor to ensure an effective and attractive installation. Any additional monitors to be added shall conform to these standards.

The 20-inch video monitors shall be full color monitors designed especially for surveillance and industrial applications. The monitor shall include a 20-inch diagonal color picture tube with integral implosion protection.

Each 20-inch monitor shall provide for 560 TV lines resolution, and shall operate off an NTSC color video input signal.

Each 20-inch monitor shall have front mounted operating controls and automatic degaussing and shall be S-VHS compatible.

The Contractor shall provide all necessary mounting brackets, rack system, and hardware to install the video monitors within the wall of the Traffic Management Center. The rack system, mounting brackets, and hardware shall secure the monitors in a stable and safe manner, allowing for access to the controls and not interfering with the normal functioning of the video monitors. The mounting brackets shall be capable of adjusting the horizontal and vertical angles of the monitors to achieve an optimum viewing position.

The 80 inch color display unit shall be a modular, 80" diagonal rear screen enclosure equipped with a high resolution chassis-style LCD projector and front slide-mount assembly for easy access during maintenance periods. The modular unit, complete with projector, shall be Part #BVSKD962IOOG-OEM, manufactured by Barco Visual Systems (148 Madison Avenue, New York, NY 10016- Phone: (212) 532~206) or approved equal. The monitor shall be capable of displaying the video images from the cameras, the video receivers, and the TATMS graphics.

The rear screen enclosure shall be constructed of welded aluminum with polypropylene covered panels. The texture and color of the enclosure's exposed sides shall be matched to fit the decor of the room. The enclosure shall meet the following specification:

- The enclosure shall measure approximately 77 inches wide by 60 inches deep by 105 inches high.
- The enclosure's 80" diagonal fresnel lenticular screen shall begin at 46 inches above the finished floor to permit unobstructed viewing from the Operator's Console.
- The enclosure Shall include a removable front panel with sliding LCD projector support assembly to allow quick access for lamp replacement.
- The enclosure shall house one (1) optical quality 94% reflective first surface glass mirror utilizing a single-fold light path design.

- The 80" diagonal fresnel lenticular screen shall be constructed of a single piece of cast acrylic material. The screen shall have the following characteristics:
 - Overall Gain Of: 5.0 +/- 0.3 on axis
 - Light Distribution: 180 degrees over horizontal plane
 - Horizontal Half-Gain Angle: 33 degrees from projection axis
 - Vertical Half-Gain Angle: 9 degrees from projection axis
 - Resolution: 1280 x 1024 pixels minimum
 - Contrast: 50:1
 - Diagonal Measurement: 80"
 - Thickness: 0.25 inches max.
 - Edge Thickness: 0.25 inches

The Contractor shall furnish and install within the enclosure a compact, chassis-style high resolution LCD projector utilizing a 575 watt metal-halide lamp. The projector shall be secured to a sliding support assembly that travels into position through the enclosure's front panel. The LCD projector shall meet the following specifications:

- Compact, Chassis Design With Built-in Slide Assembly
- Removable Panel For Quick Lamp Replacement
- 2000-Hour Lamp (User Replaceable)
- High Definition 1.15:1 Short Throw Lens
- Single 10.4" LCD Panel - 1024 x 768 Resolution
- Intelligent Pixel Map Processor Circuitry For 1280 x 1024
- 750 ANSI Lumens Brightness
- Custom Color Temperature Adjustment
- (2) Computer Inputs; (3) Video Inputs; S-VHS - Composite - Component
- Digital Image Size, Freeze, and Enlarge Features
- RS-232 Serial Control Port
- On-Screen Menus
- Ten Programmable and Selectable Source Settings
- ISO 9001 Certification
- FCC Part 15 Class B Compliance For EMI

The Contractor shall furnish all required cables and interfaces necessary for the operation of the display system.

686-4.5 Video Receiver

The Contractor shall furnish and install two (2) video receivers capable of receiving a cable television signal and converting it into an input to the video switcher. Each video receiver (consisting of a demodulator, tuner, and an audio amplifier) shall be utilized for receiving and displaying live cable television programming (i.e., the Weather Channel, local access government channel) on a video display monitor. The receivers shall be integrated into the rack cabinet system housing the control equipment. High quality speakers for the audio outputs shall be provided and located so as to be clearly heard at the system control console in the Transportation Management Center. A remote control system allowing the tuning of the receivers and the control of the volume, from the console, shall also be provided.

686-4-6 Field Video Monitors / Portable Controllers

The Contractor shall furnish two (2) field video monitors for use in the field calibration and testing of the video camera assemblies. Each field video monitor shall consist of a 5-inch black-and-white display, suitably housed within a rugged, portable carrying case, and shall be provided with the necessary connectors and an AC or DC power supply to be able to operate with the camera assemblies in the field.

The Contractor shall furnish one (1) field high performance controller unit. The unit shall interface with the local control panel and provide local control of the Pan, Tilt, and Zoom functions and allow programming of camera presets. The unit shall be suitably housed within a rugged, portable carrying case, and shall be provided with the necessary connectors and an AC or DC power supply to be able to operate with the camera assemblies in the field.

The Contractor shall furnish one (1) field joystick controller unit. The unit shall interface with the local control panel and provide local control of the Pan, Tilt, and Zoom functions. The unit shall be suitably housed within a rugged, portable carrying case, and shall be provided with the necessary connectors and an AC or DC power supply to be able to operate with the camera assemblies in the field.

686-5 Video Subsystem Training

The Contractor shall provide a minimum of eight (8) hours training for a minimum of ten (10) engineering and operations personnel. The training course shall include the complete demonstration of the operation and capabilities of the video monitoring subsystem, and shall include a complete review of the programming or setup of the equipment which may be necessary for the operation of the system. Training should emphasize the day-to-day operation of the equipment and the isolation of problems down to the unit level.

The Contractor shall also provide a minimum of sixteen (16) hours training for a minimum of ten (10) electronics maintenance personnel. This training course shall include the complete demonstration of the capabilities of the equipment, preventative maintenance requirements and procedures, and troubleshooting activities.

All training shall be conducted by factory trained personnel at a site provided by the City of Tallahassee. All training materials, including manuals, schematics, and other

documentation, shall be provided by the Contractor. A minimum of two weeks prior to the initiation of the classes, the Contractor shall submit detailed course content and schedule information for review and approval by the Engineer.

686-6 Video Subsystem Burn-in and Testing

The completed Video Monitoring Subsystem shall operate for a 7-day burn-in period to identify any potential problems or infant mortality issues with the equipment. Upon the completion of the burn-in period, the system shall undergo an acceptance test process.

A minimum of two weeks prior to the start of testing, the Contractor shall develop and submit to the Engineer a test procedure and schedule for testing the system. The Contractor shall then thoroughly test the operation and performance of the Video Monitoring Subsystem in accordance with the approved test procedure and shall submit the results in a signed test report.

686-7 Documentation

The Contractor shall furnish complete documentation for all equipment furnished and installed as part of this contract. The documentation shall include complete details and descriptive literature covering system operation, system construction, and system interfaces, together with complete operating and maintenance requirements and information. The documentation shall include standard manuals for all manufacturer supplied equipment and a system block diagram.

The documentation shall include an equipment list which contains the quantity of each component supplied, model numbers, serial numbers, manufacturer's name and address, servicing vendor or distributor, phone, fax, e-mail address, and warranty information.

The documentation shall include as-built plans for the layout of the video switching and control equipment which correctly describes the installation of the video equipment, including the location of the equipment and the routing of all cables.

686-8 Warranty

All video monitoring subsystem equipment provided under this contract shall include a one year parts and labor warranty. The one year period will initiate upon the date of final acceptance of the video monitoring subsystem.

686-9 Method of Measurement

The Type I Closed Circuit Television Camera Assembly shall be measured in complete units consisting of the camera, lens, dome enclosure, pan-tilt mechanism, mounting bracket, field located control electronics, cabling, and all related hardware and miscellaneous equipment as necessary for a complete installation as defined in these Technical Special Provisions.

The Video Monitoring Subsystem Communications Equipment shall be measured in complete units consisting of the field located transceivers, central site transceivers, central site rack and cabinet assembly, cables, and all related hardware and miscellaneous equipment as necessary for a complete installation as defined in these Technical Special Provisions.

The Central Control Equipment shall be measured in complete units consisting of the video switcher, video control system, display monitors, video receivers, field video monitors and portable controllers, video system diagnostic software, documentation, and all related and miscellaneous hardware and equipment necessary for a complete and operational installation as defined in these Technical Special Provisions.

The Video Monitoring Subsystem Training Course shall be measured in complete units consisting of the training, materials, labor, and all related and miscellaneous equipment necessary for a complete course as defined in these Technical Special Provisions.

686-10 Basis of Payment

UNIT PRICE COVERAGE

The accepted work of furnishing and installing the video monitoring subsystem equipment, measured as noted above, shall be paid for at the contract unit price bid, which shall be full compensation for the satisfactory provision, set up and installation of the equipment, in accordance with these Technical Special Provisions, and for all equipment, tools, labor, services, permits, insurance, and incidentals necessary to complete the work.